

# INCOSE/OMG MBSE Initiative PBSE Patterns Challenge Team



Meeting: September 30, 2014

(Schedule adjustable as needed)

## Meeting Agenda

### INCOSE PBSE Patterns Challenge Team (of MBSE Initiative)

Web Conference Meeting: Tuesday, September 30, 2014, 4:00 – 5:30 PM EST

Pre-Reading for this meeting: Materials of team meeting, Sept 15, 2014	
General background, earlier meetings: Team web site on MBSE wiki: <a href="http://www.omgwiki.org/MBSE/doku.php?id=mbse:patterns:patterns">http://www.omgwiki.org/MBSE/doku.php?id=mbse:patterns:patterns</a>	
<u>Meeting start up:</u> <ul style="list-style-type: none"> <li>Review of meeting objectives and agenda</li> </ul>	4:00 – 4:05 PM EST
<u>Challenge Team Current Projects:</u> <ul style="list-style-type: none"> <li>List of known team projects in progress or starting</li> <li>General goals of these projects and related team charter objectives</li> <li>Plans for related IS2015 (November 9 submission) and GLRC2014 (submissions now closed) papers</li> </ul>	4:05 – 4:15
<u>Walk-through of next segments of S*Pattern(s):</u> <ul style="list-style-type: none"> <li><u>Interactions &amp; States Model</u> (configurable) <ul style="list-style-type: none"> <li>Purpose</li> <li>Examples from current project pattern(s)</li> <li>Q&amp;A</li> </ul> </li> <li><u>Detail Interactions &amp; Requirements Model</u> (configurable): <ul style="list-style-type: none"> <li>Purpose</li> <li>Examples from current project pattern(s)</li> <li>Q&amp;A</li> </ul> </li> <li>Plans for next segment of S* Pattern(s): Requirements Attributes, Attribute Couplings (configurable)</li> </ul>	4:15 – 5:15
<u>Planning Next Activities:</u> <ul style="list-style-type: none"> <li>Future pattern review meetings schedule, by pattern segment</li> <li>Plans for IW2015 joint MBSE Workshop session by Patterns Team and Agile Systems Working Group</li> <li>Outreach: Who else should be involved?</li> </ul>	5:15 – 5:30
<u>Closing:</u> <ul style="list-style-type: none"> <li>Contact information</li> <li>Adjourn</li> </ul>	5:30

Example reviewed last time; your patterns this time

Example review this time; your patterns next time

For more information, contact-- Bill Schindel [schindel@ictt.com](mailto:schindel@ictt.com)

Troy Peterson [peterson\\_troy@bah.com](mailto:peterson_troy@bah.com)

- Primary objective of today's meeting:
  - Review next segments of the team's project patterns
- This Challenge Team is concerned with configurable, re-usable system models, called "S\*Patterns":
  - Models containing a certain minimal set of elements are called S\*Models
  - May be expressed in any modeling language (e.g., SysML, or other)
  - Re-usable, configurable S\*Models are called S\*Patterns
  - By "Pattern-Based Systems Engineering" (PBSE) we mean MBSE enhanced by these generalized assets
  - These are system-level patterns (models of whole managed platforms), not smaller-scale component design patterns
- These are the team's pattern projects known to be underway:
  - Multi-domain product/manufacturing process example (Oil Filter Family) (Bill Schindel, Stephen Lewis, Saumy Sanyal, David Cook)
  - Mil/Aero Electronic Systems (Tamara Valinoto)
  - RC / Autonomous Car (Troy Peterson)
  - Verification Systems (Andy Pickard)

# Walk-through of some initial S\*Pattern segments

- **Functional Interaction**: Physical interactions, in which energy, force, mass, or information is exchanged between components. Can occur when the system is in a particular State.
- **Input-Output**: Energy, Force, Mass, or Information exchanged during Interactions.
- **Interface**: An association of a System (which has the interface), a set of Input-Outputs (which flow through the interface), a set of Interactions (which describe behavior at the interface), and a System of Access (which provides the external medium of interaction).
- **System of Access**: An external system providing an external medium of interactive exchange.
- **State**: Modes, Phases, Situations, having duration in time, during which some Interactions are eligible to occur and others are not.

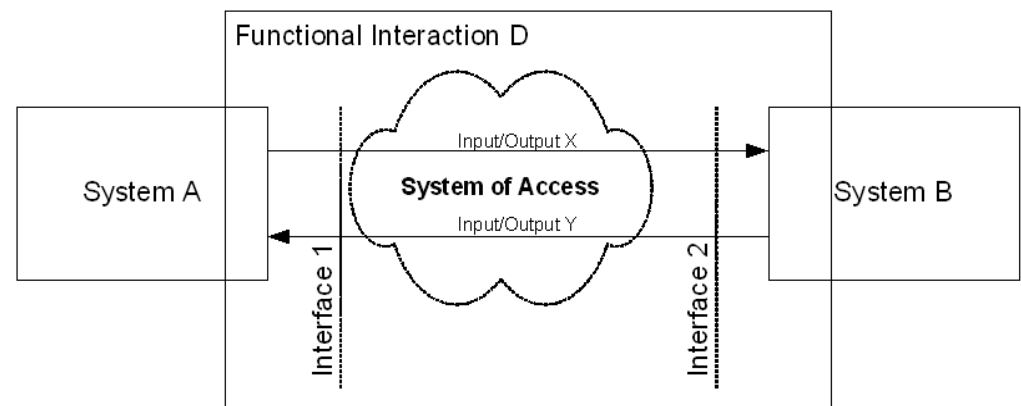
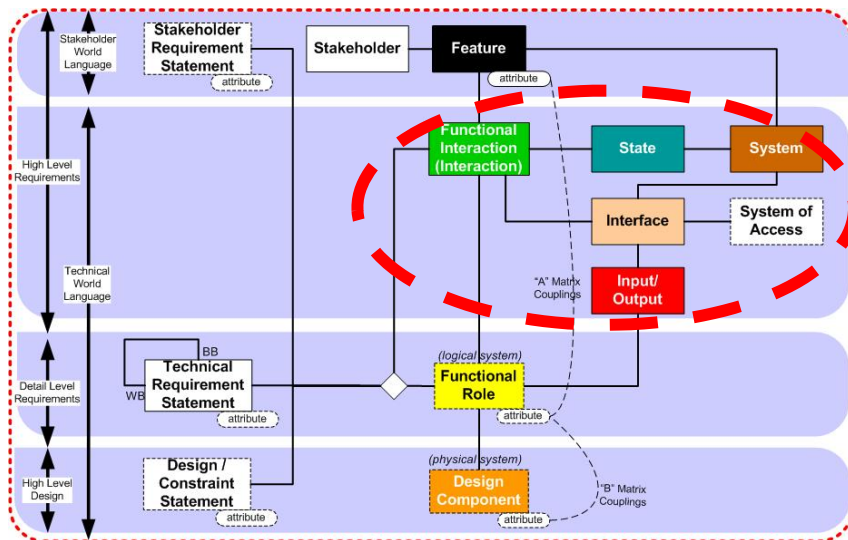

System Interactions, Systems of Access, Interfaces

Once we establish a Pattern for a Platform or Product Line System, specific configurations are generated by selection (population) of Features, and setting values for Feature Attributes.

# An example S\*Pattern Extract

Lubricant (Oil) Filter Product Family

# Example S\*Pattern Stakeholder Feature Overview Model

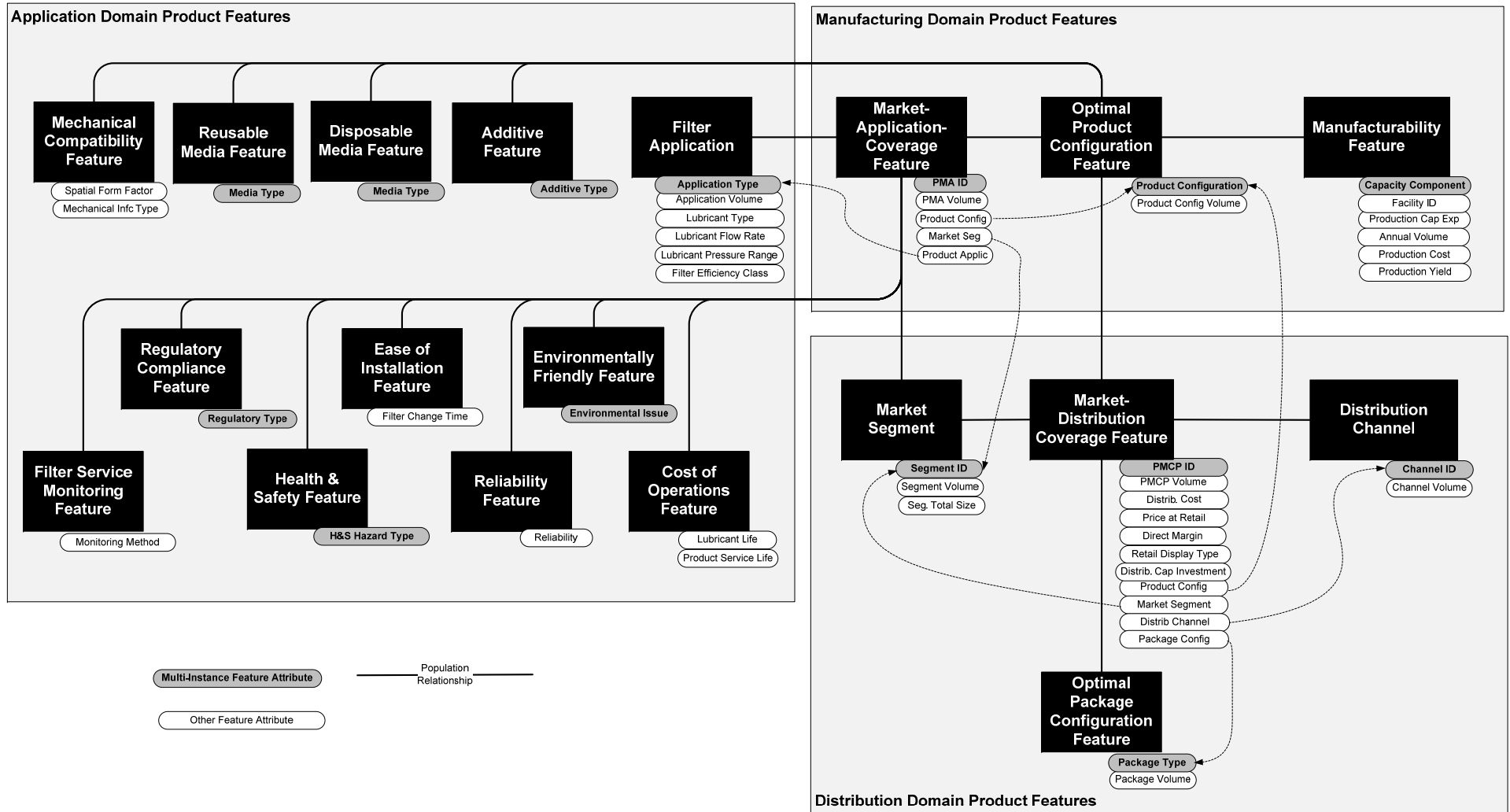

# Example S\*Pattern Stakeholder Feature Model Extract

Feature	Feature Attribute	Multi-Instance	Attribute Definition	Attribute Units	Attribute Values
Optimal Product Configuration Feature	Product Configuration	X	Identifies the configuration of the product, as a model ID. Multiple configurations may be populated.	N/A	
Optimal Product Configuration Feature	Product Configuration Volume		The number of units of this product configuration produced per year.	Units/Year	
Filter Application	Application Type	X	The type of lubricated system application supported by a lubricant filtration system. More than one type may be instantiated for a single product configuration.	N/A	Consumer Automotive, Commercial Automotive, Fixed Base Engine System, Harsh Environment, High Temperature Environment, Cold Environment
Filter Application	Application Volume		The number of units of this application placed into service during a year.	Units/Year	
Filter Application	Lubricant Type		The type of lubricating fluid to be used.	N/A	
Filter Application	Lubricant Flow Rate		The rate at which the lubricating fluid must be circulated in order to meet equipment lubrication objectives.	GPM	High, Medium, Low
Filter Application	Lubricant Pressure Range		The amount of hydraulic pressure under which the lubricant will circulate.	PSI	High, Medium, Low
Filter Application	Filter Efficiency Class		The profile of filtration efficiency provided by the filter	N/A	
Mechanical Compatibility Feature	Spatial Form Factor		The class of three dimensional structure of a component, subsystem, or space within a system reserved for a component or subsystem.	N/A	
Mechanical Compatibility Feature	Mechanical Interface Type		The mechanical class of the interface between the oil filter and the equipment to which it is connected.	N/A	
Cost of Operation Feature	Lubricant Life		The amount of time that a lubricant is intended to operate, meeting requirements within the specified environment, before it is replaced.	Hours	

# Example S\*Pattern Stakeholder Feature Overview Model

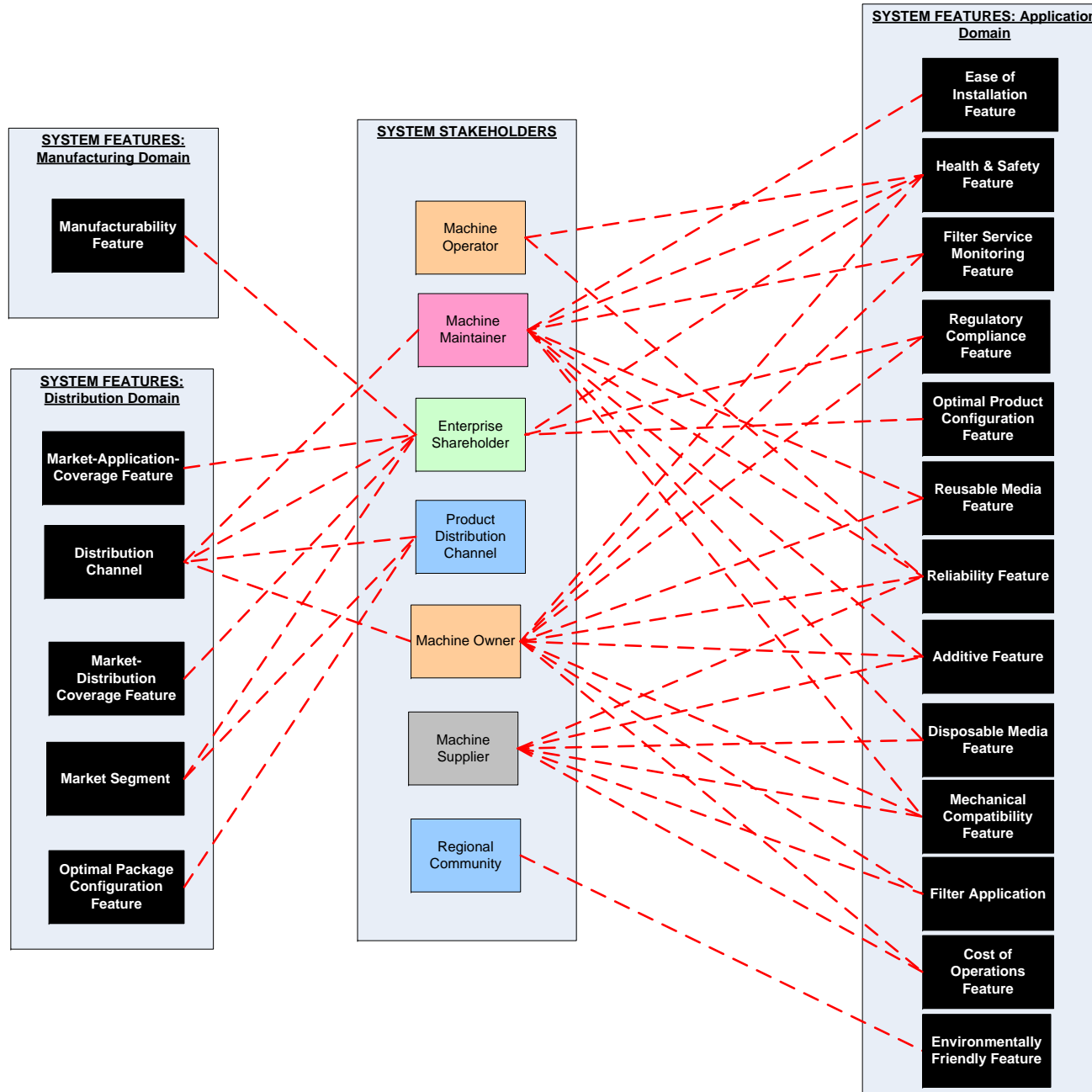





# Examples from Enterprise Architect (a SysML Modeling Tool)

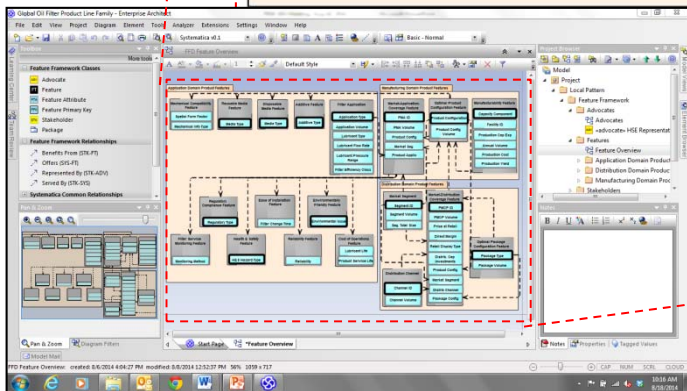
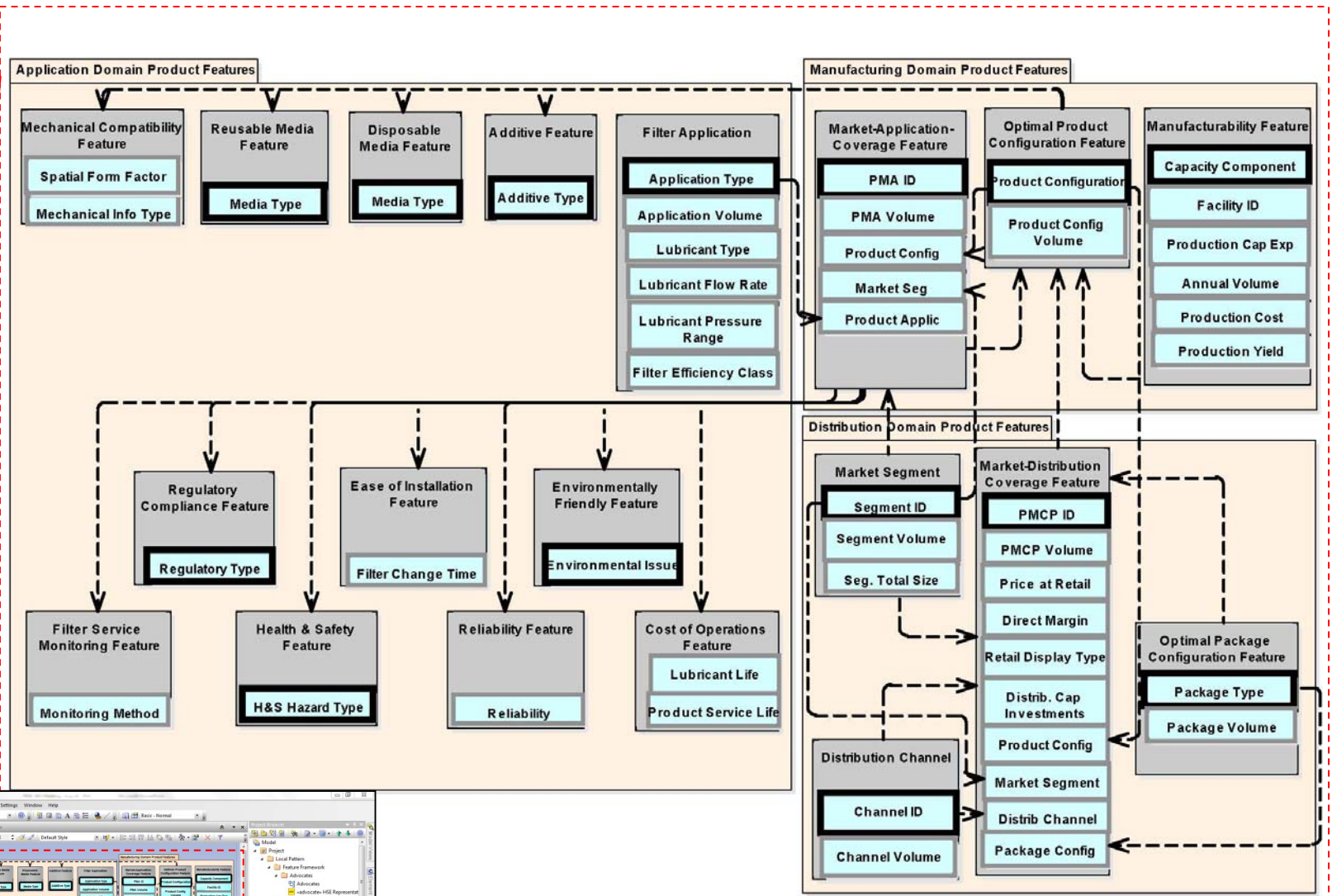

	Enterprise Shareholder	Machine Maintainer	Machine Operator	Machine Owner	Machine Supplier	Product Distribution Channel	Regional Community
Additive Feature		↑		↑	↑		
Cost of Operations Feature				↑			
Disposable Media Feature		↑		↑	↑		
Distribution Channel	↑	↑		↑		↑	
Ease of Installation Feature		↑					
Environmentally Friendly Feature							↑
Filter Application				↑	↑		
Filter Service Monitoring Feature		↑		↑			
Health & Safety Feature		↑	↑	↑			
Manufacturability Feature	↑						
Market-Application-Coverage Feature	↑						
Market-Distribution Coverage Feature	↑						
Market Segment	↑						↑
Mechanical Compatibility Feature		↑		↑	↑		
Optimal Package Configuration Feature	↑						↑
Optimal Product Configuration Feature	↑						
Regulatory Compliance Feature				↑			
Reliability Feature		↑	↑	↑	↑		
Reusable Media Feature		↑		↑			

Examples from  
Enterprise Architect  
(SysML Modeling Tool)

Discussion of your Patterns . . .

Stakeholders, Features

# External “domain model” for System of Interest

- Will later help us identify all the external interactions with System of Interest.
  - **So what?** All system black box requirements are identified with (may be discovered through) those interactions.
- Domain diagram shows Actors, Interfaces, Input-Outputs or Relationship--:
  - **Actors**: People or other Systems that directly interact with the system of interest, by exchanges of force, energy, mass, or information.
  - **Input-Outputs**: The exchanged forces, energy, mass, or information.
  - **Domain Architecture Relationships**: Alternative way to summarize input-outputs
  - **Interfaces**: Associations of Systems (that “have” the interfaces), Input-Outputs (that “pass through” the interfaces), Interactions (that “describe behavior” at interfaces, and Systems of Access (that provide the external media of interaction).

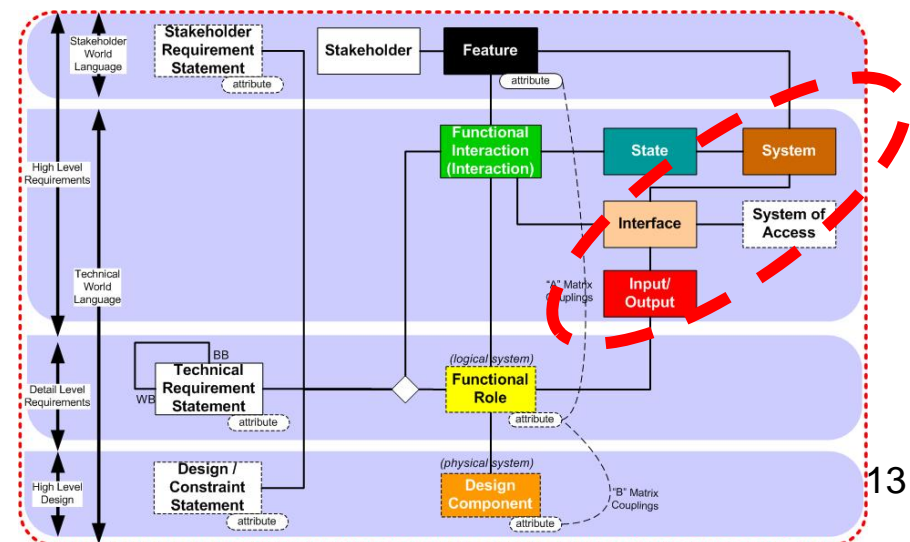

# Domain model for Oil Filter System

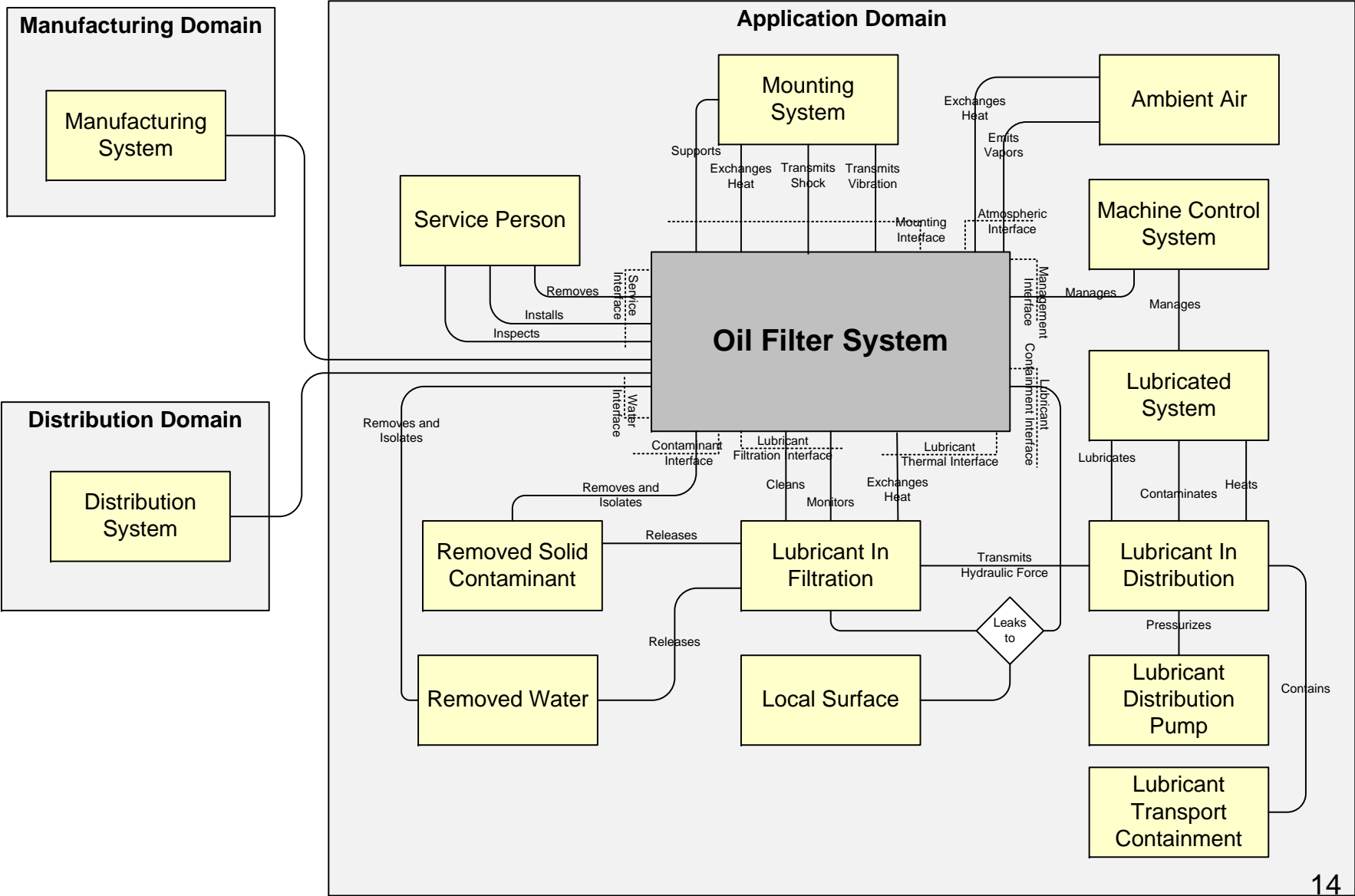

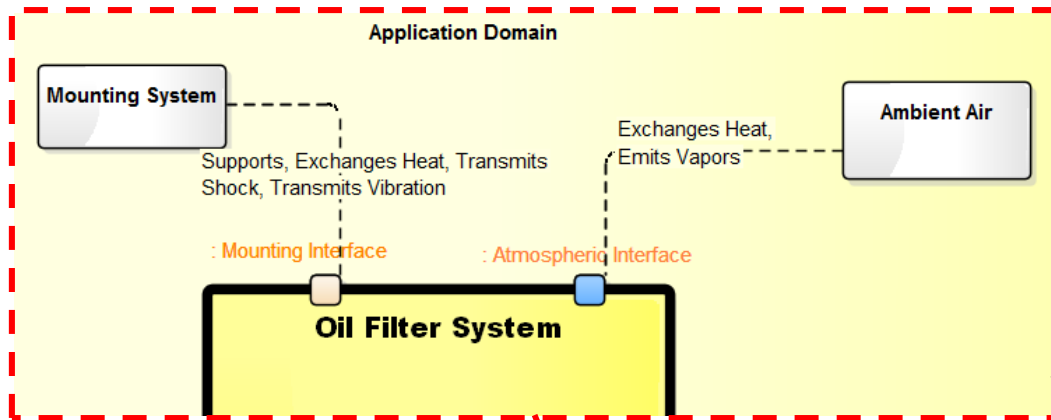

Extract from equivalent SysML Domain Model, in EA Tool

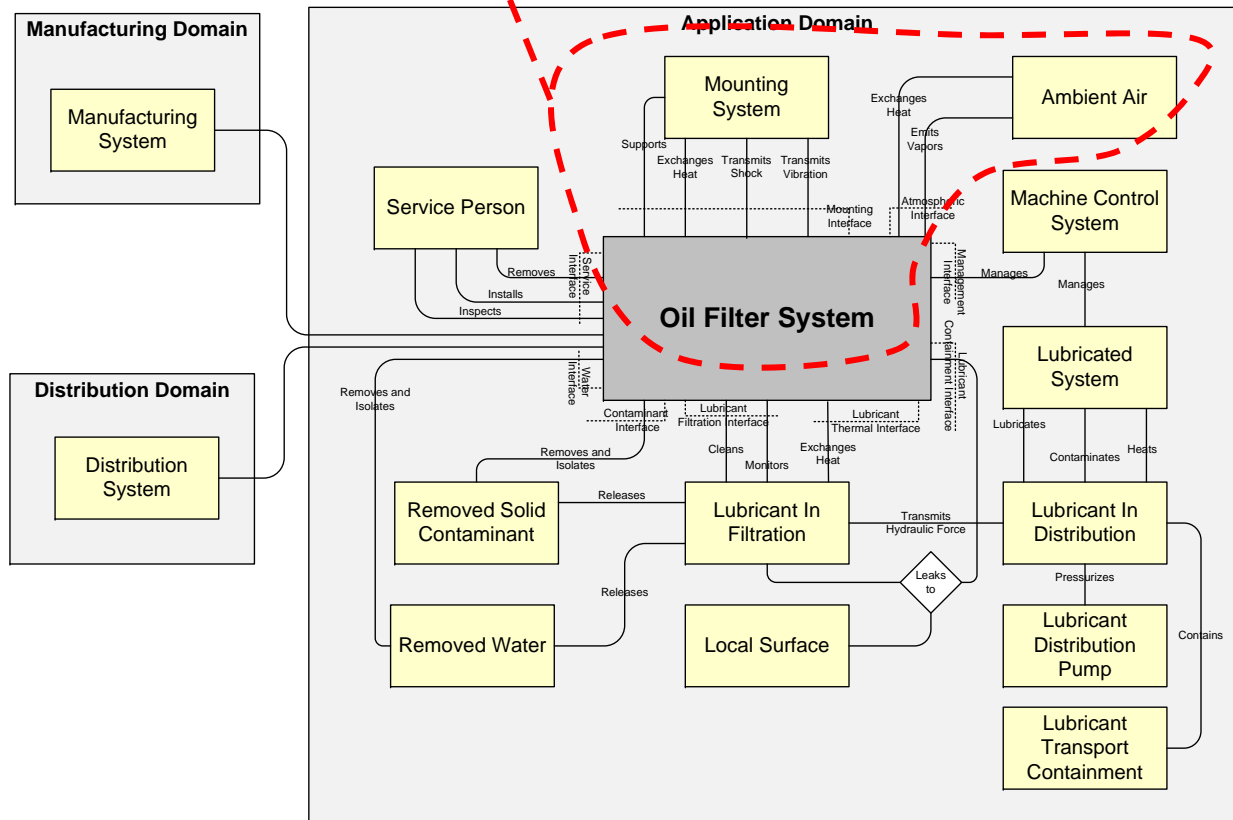
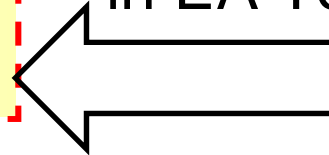

# Domain model for Manufacturing System (of Oil Filter)

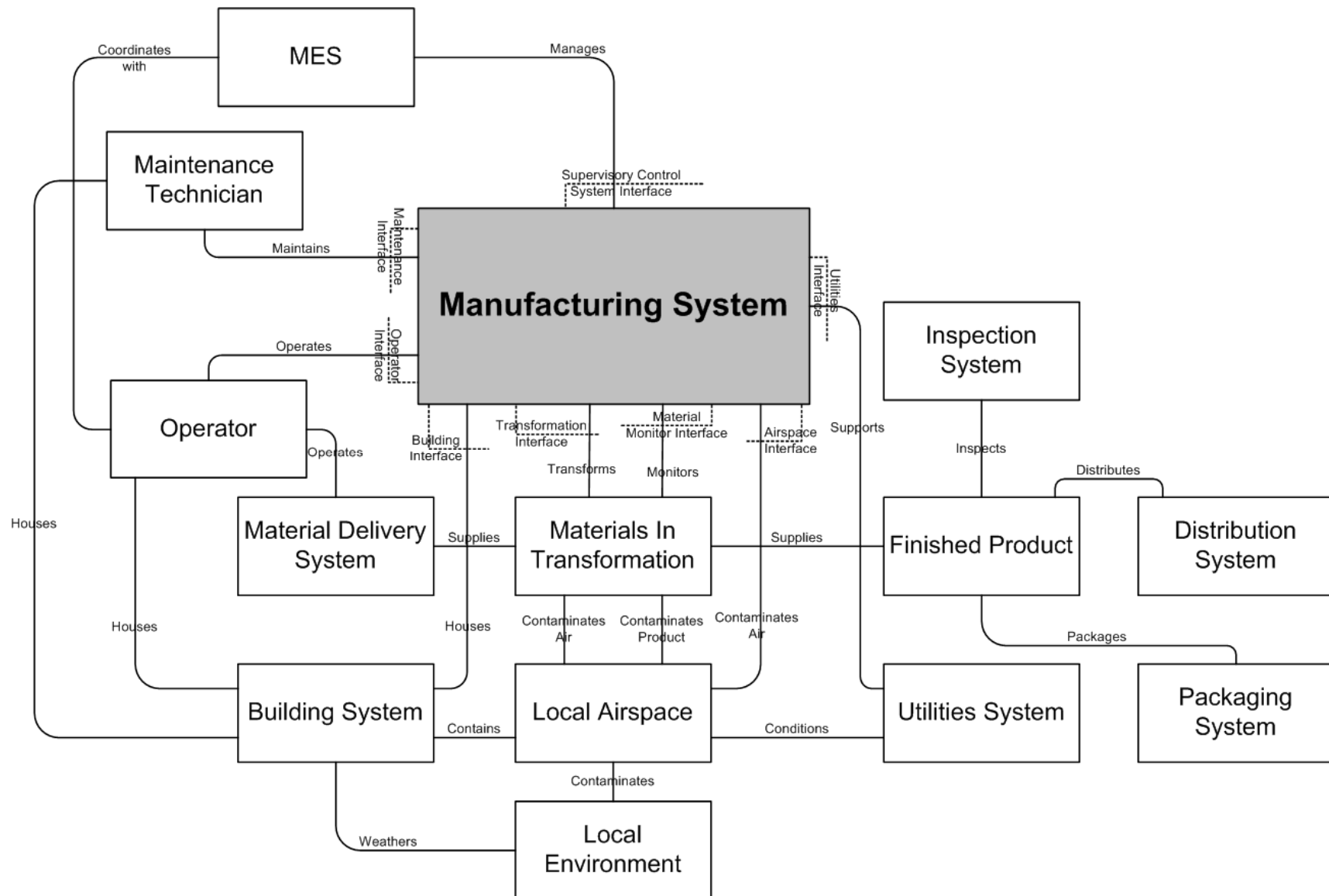



- Challenge Team goal for second half of 2014:
  - Make enough sub-team progress on selected patterns important to members to support . . .
  - One or more related INCOSE IS2015 papers for Seattle (paper drafts due Nov 2014, complete in Mar 2015—two currently known in progress)
  - One or more related INCOSE GLRC2014 presentations for Chicago (October, 2014—one currently known accepted)
- In support of this goal:
  - Bill Schindel is holding bi-weekly, web-based pattern review sub-team work sessions (e.g., 90 minutes) throughout the second half of 2014
  - Typically meet every other Monday, 4:00 – 5:30 PM EST (like today's)
  - Purpose of these sessions to assist sub-teams in preparing S\*Patterns conforming to S\*Metamodel and meeting each team's application goals.

Sessions	Configurable S*Pattern Construction
Aug	Configurable Features Model; Domain Model
Sep	Domain Model; Interactions; States
Oct	Detail Interactions; Requirements; Attribute Couplings
Nov	Logical Architecture; Detail Interactions; Requirements
Dec	Physical Architecture; Failure Modes
Jan	More about configuration rules

# Scheduling and communications

- Currently planned next meeting dates:

- Tuesday, Sep 30, 4:00 – 5:30 PM EST
- Tuesday, Oct 14, 4:00 – 5:30 PM EST
- Tuesday, Oct 28, 4:00 – 5:30 PM EST

- Team web site:

<http://www.omgwiki.org/MBSE/doku.php?id=mbse:patterns:patterns>

## Related Activities by Other WGs and MBSE Initiative

- Working with Rick Dove (Agile Systems WG, Security WG) on an IW2015 MBSE Workshop break-out session:
  - On Agile Systems, System Patterns, and Composable Systems
- We'd like to have cooperative activities with other WGs:
  - e.g., Biomedical / Healthcare
- Other groups in the MBSE Initiative are creating a cloud resource for working groups and teams such as ours:
  - On-line shared models repository, for sharing models
  - On-line access to limited set of tool vendor licenses, for use in INCOSE projects
- News from other members, WGs:
  - 
  -
- To whom else should we be reaching out?
  -

Back up materials—from earlier meetings of this Challenge Team

# Patterns Demand Strongest Underlying Models

- The S\*Metamodel describes the smallest set of ideas necessary to model a system for purposes of engineering or science:
  - Most of them familiar to modelers, and all of them basic to the training of engineers and scientists—*but not always found in their system models.*
  - A metamodel is a model of other models;
  - Sets forth underlying concepts of Requirements, Designs, Failures, Trade-offs, etc. (not modeling language syntax)
- The resulting S\*Models may be expressed in SysML or other modeling languages, and constructed / reside in numerous commercial tools and information systems.
- Has been applied to SE in aerospace, transportation, medical, advanced manufacturing, communication, construction, consumer, other domains.

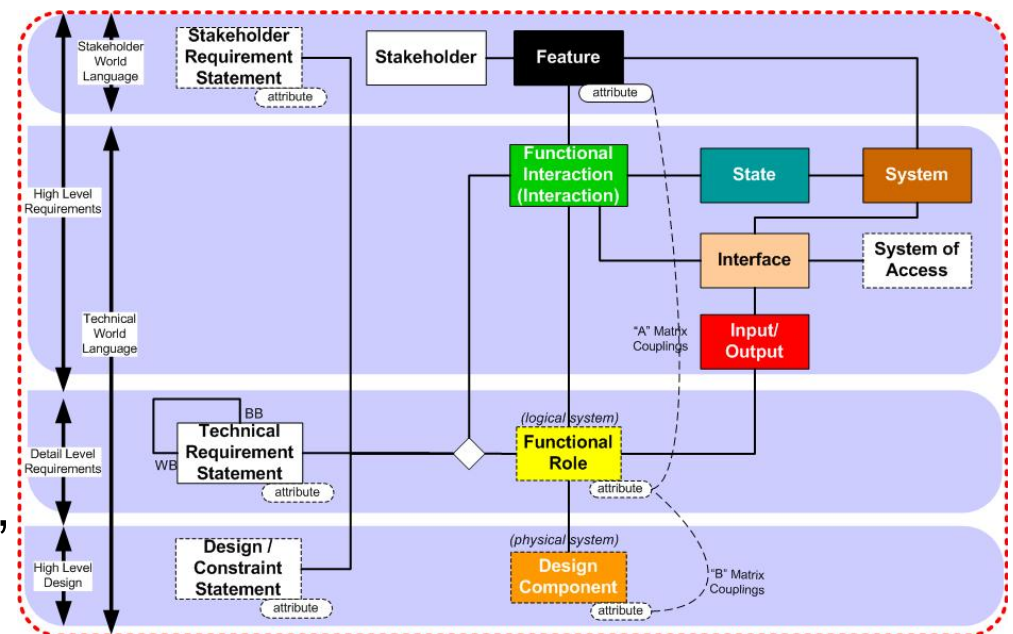

- The PBSE approach respects the systems engineering tradition, body of knowledge, and historical lessons, while providing a high-gain path forward.
- *An S\* Pattern is a configurable, re-usable S\* Model.* It is an extension of the idea of a Platform (which is a configurable, re-usable design). The Pattern includes not only the Platform, but all the extended system information (e.g., requirements, risk analysis, design trade-offs & alternatives, decision processes, etc.):

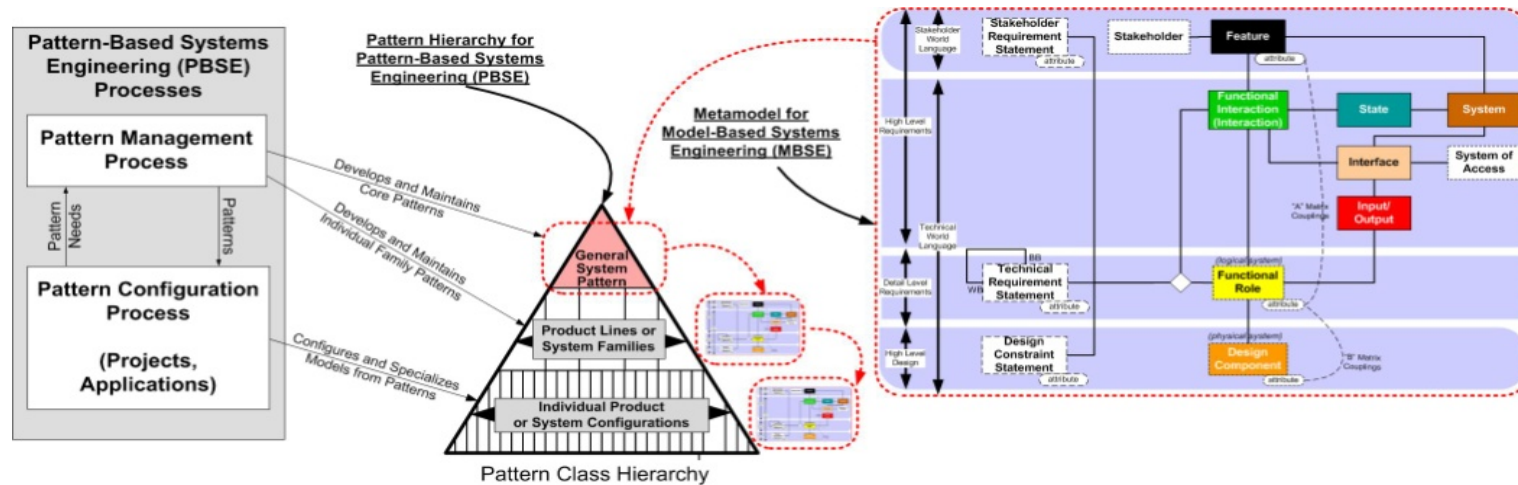

- By including the appropriate S\* Metamodel concepts, these can readily be managed in (SysML or other) preferred modeling languages and tools—the ideas involved here are not specific to a modeling language or specific tool—ported to several.
- The order-of-magnitude changes have been realized because projects that use PBSE rapidly start from an existing Pattern, gaining the advantages of its content, and feed the pattern with what they learn, for future users.
- The “game changer” here is the shift from “learning to model” to “learning our (your) model”, freeing many people to rapidly configure, specialize, and apply patterns to deliver value in their model-based projects.

# A little more about S\*Patterns

- Fixed (Pattern) Portion, Variable (Configuration) Portion, and the Configuration Process:
  - The generalized S\*Pattern is expressed in exactly the same S\*Metamodel classes and relationships as a specific configured S\*Model derived from it.
  - “Configuring” a pattern means a process limited to exactly two things:
    - Populating (or de-populating) instances of classes and relationships
    - Setting the values of attributes (parameters)

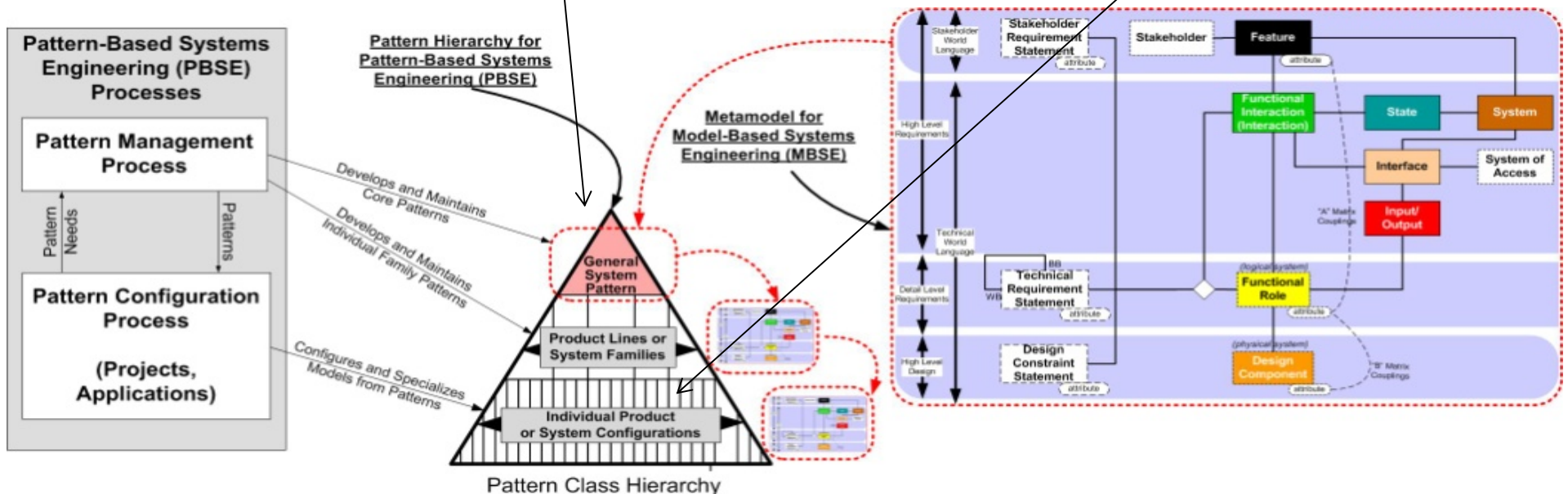

## A little more about S\*Patterns

- Having an S\*Pattern meeting the underlying S\*Metamodel demands has some surprising positive consequences beyond basic benefits of MBSE:
  - The Stakeholder Feature portion of the pattern directly generates a formal Trade Space / Scoreboard for arguing, defending all decisions.
  - “Configuring” the (low dimension) Stakeholder Feature portion of the Pattern for a specific project or system configuration can “automatically” generate the (high dimension) configured Technical Requirements for that system configuration.
  - For a sufficiently built-out S\*Pattern, the same applies to the System Design (physical architecture, allocations, attribute couplings, etc.).
  - The S\*Pattern can rapidly generate very complete first draft FMEA tables, since S\*Features lead directly to modeled Effects, S\*Requirements lead directly to modeled Counter-Requirements (functional failures), S\*Design Components lead directly to modeled Failure Modes, and combinatorial FMEA analyses of the three together may be rapidly generated by machine matching algorithm.
- All these produce much faster initial drafts that are much more complete and consistent than manual approaches, but which can (should) still be subject to the normal human SME review and update:
  - We are not suggesting turning our thinking and fate over to the model, without human judgment, expertise, etc.



# Example S\*Pattern Application Domain Model

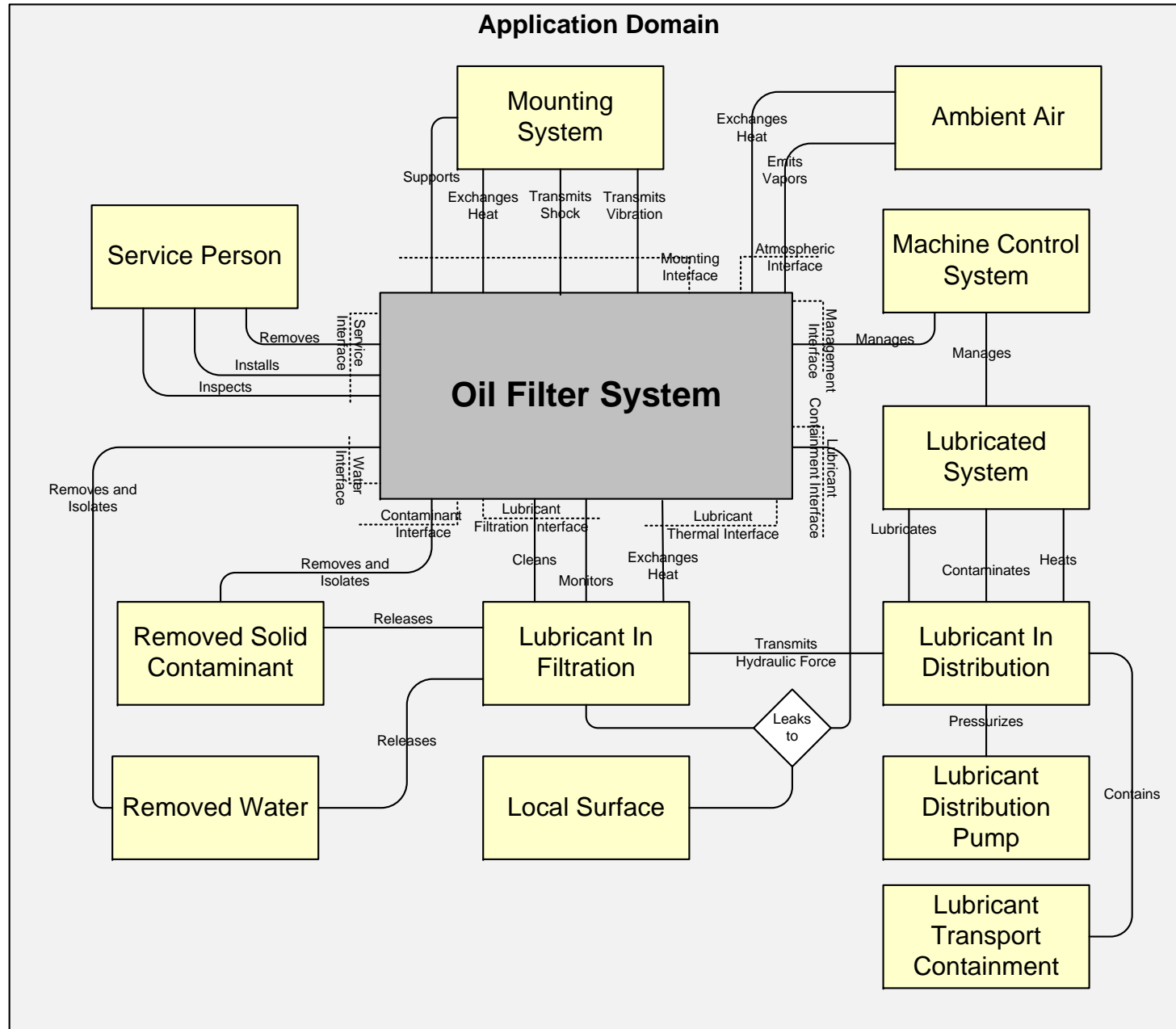

# Example S\*Pattern Manufacturing Domain Model

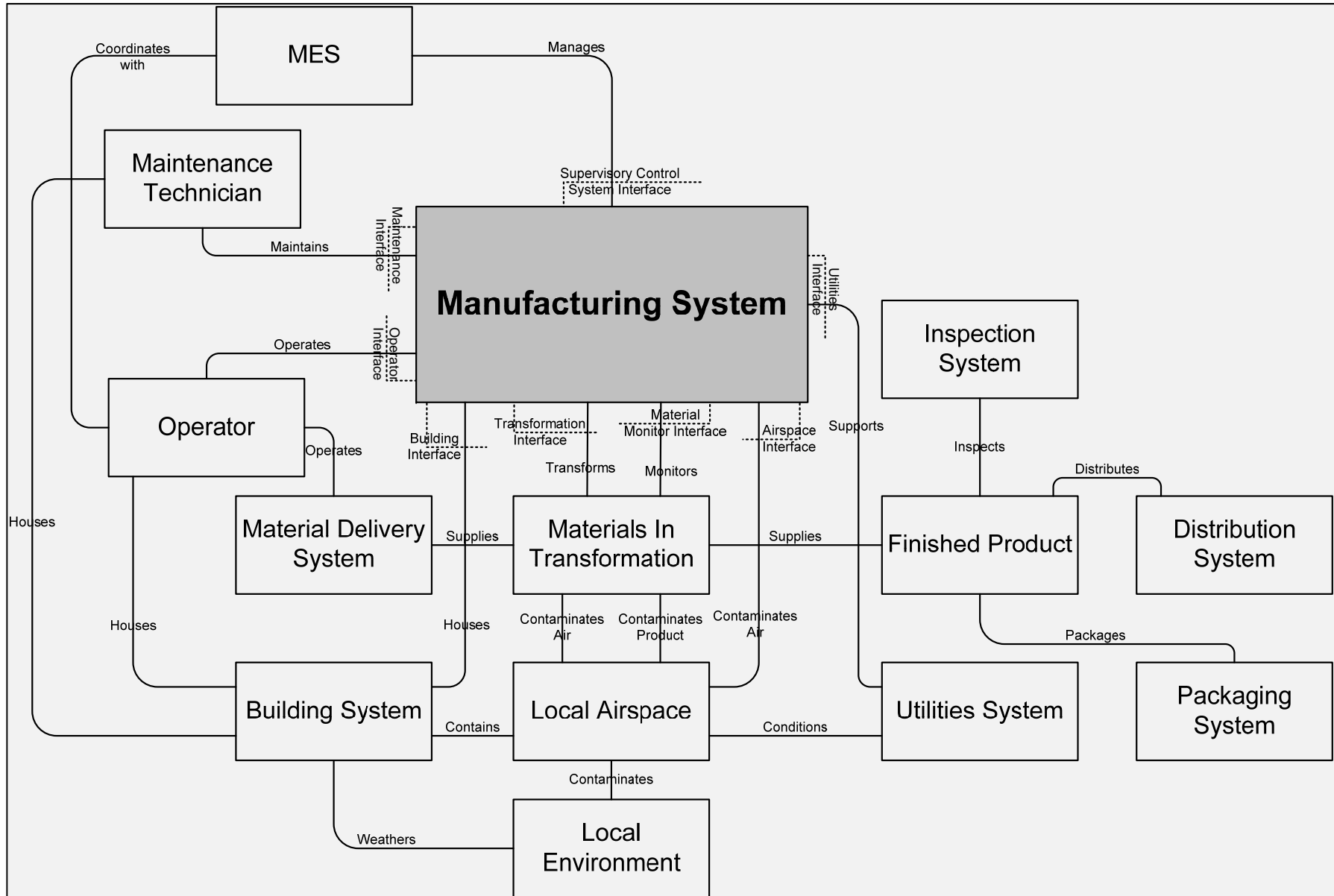

# Example S\*Pattern State (Modes) Model

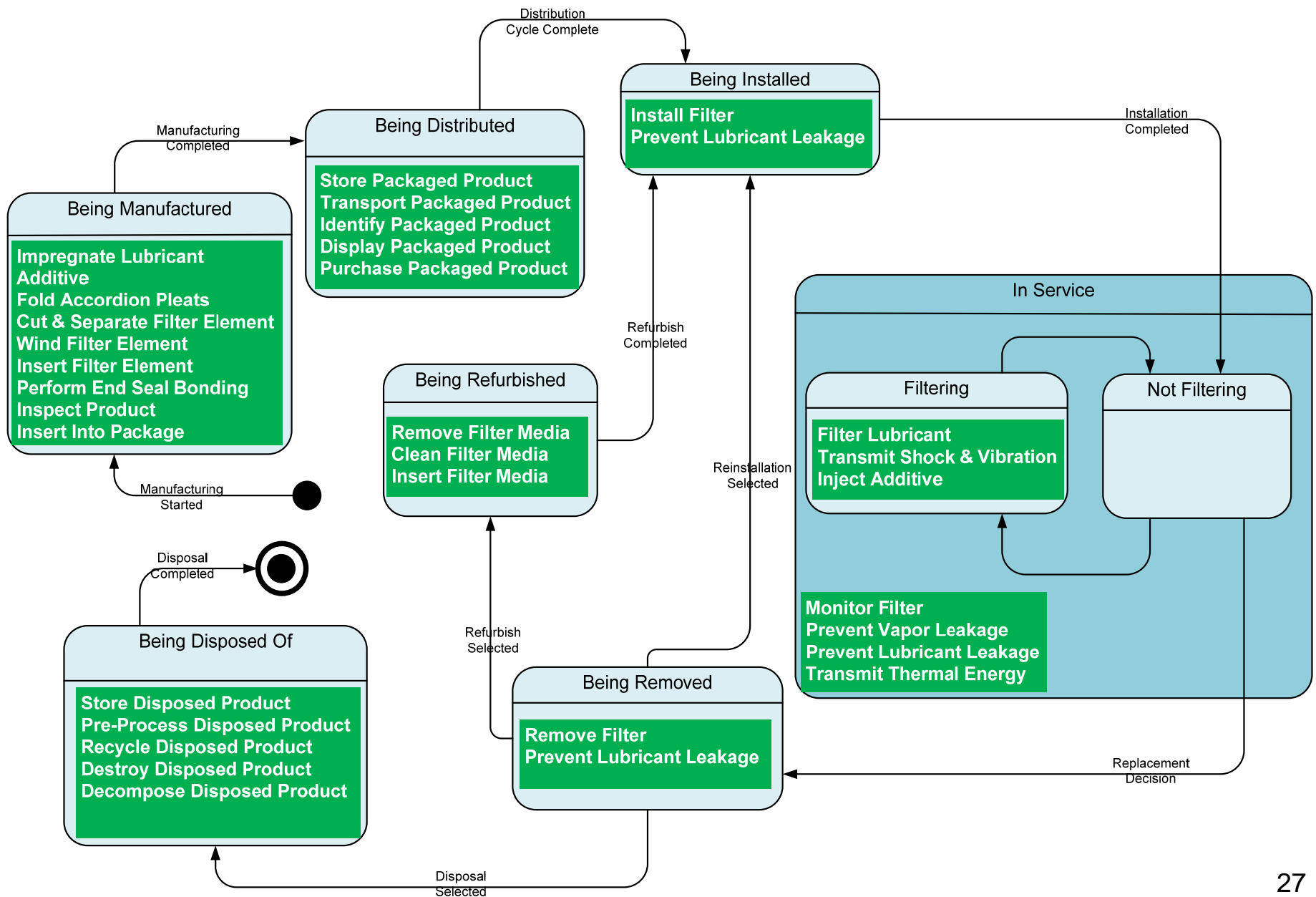

# Example S\*Pattern Interaction Overview Model

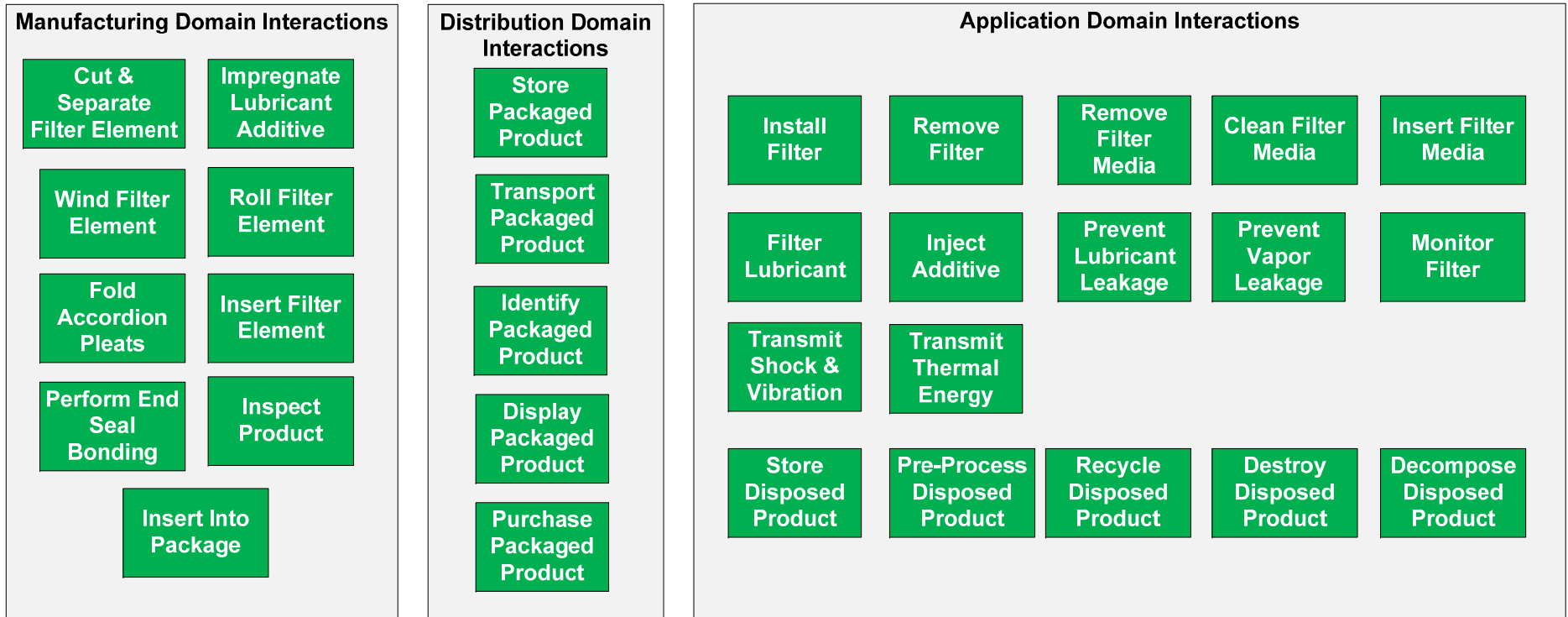

# Example S\*Pattern Feature-Interaction Associations Model (Part of Pattern Configuration Model)

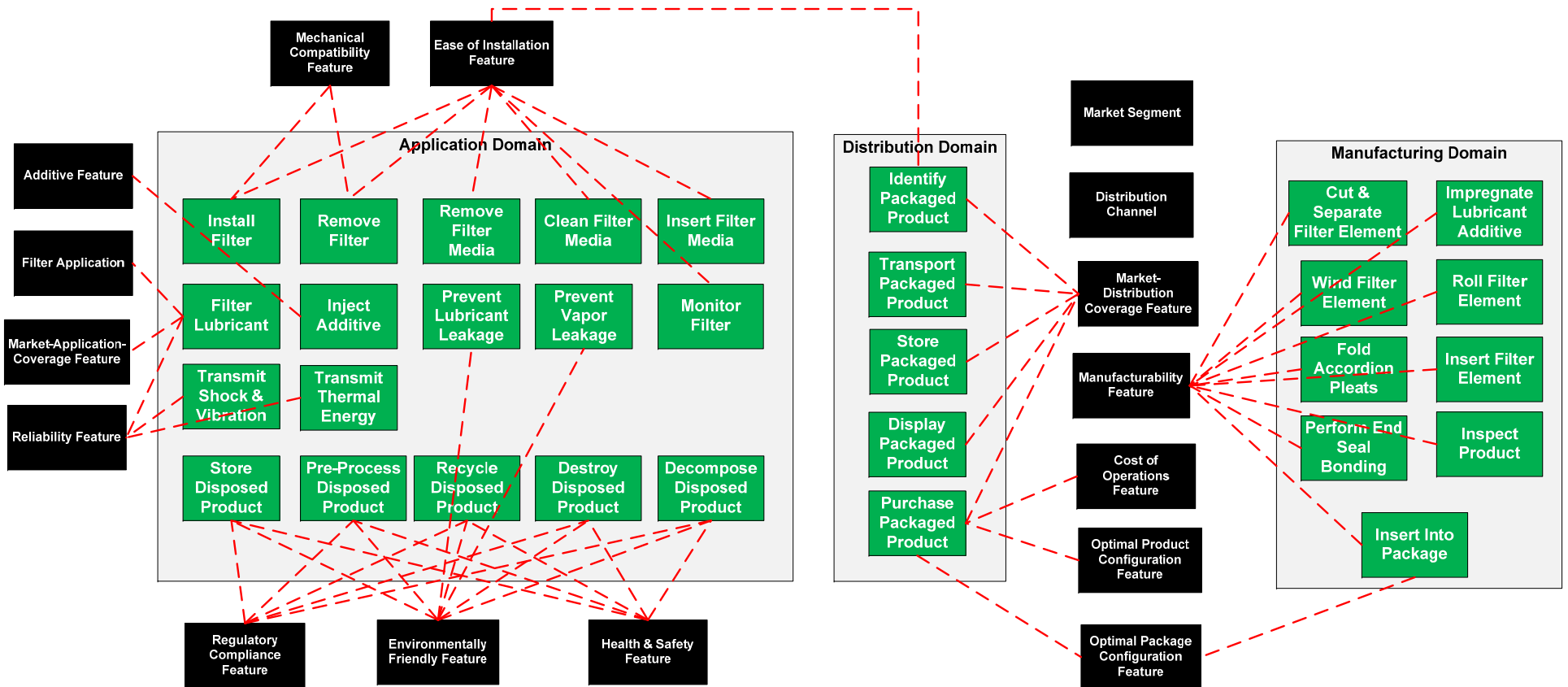

# Example S\*Pattern Interaction Overview Model Extract

Interaction Name	Interaction Definition	Oil Filter System	Service Person	Mounting System	Ambient Air	Removed Solid Contaminant	Lubricant In Filtration	Removed Water	Local Surface	Lubricated System	Lubricant In Distribution	Lubricant Distribution Pump	Lubricant Transport Containment	Waste Management System	Manufacturing System	Distribution System	Package	Buyer
Filter Lubricant	The interaction during which the oil filter system filters the lubricant in filtration.	X		X		X	X	X		X	X	X	X					
Impregnate Lubricant Additive	The interaction during which the manufacturing system impregnates the oil filter with lubricant additive.	X													X			
Fold Accordion Pleats	The interaction during which the manufacturing system folds the sheet oil filter element into the form of accordion pleats.	X													X			
Cut & Separate Filter Element	The interaction during which the manufacturing system cuts and separates individual oil filter elements.	X													X			
Wind Filter Element	The interaction during which the manufacturing system winds the fiber oil filter element into a cylindrical shape.	X													X			
Insert Filter Element	The interaction during which the manufacturing system inserts the filter element into the filter housing.	X													X			
Perform End Seal Bonding	The interaction during which the manufacturing system bonds the end seal of the oil filter.	X													X			
Inspect Product	The interaction during which the manufacturing system inspects the finished oil filter product.	X													X			
Insert Into Package	The interaction during which the manufacturing system inserts the finished oil filter product into the package.	X													X	X	X	
Remove Filter Media	The interaction during which maintainer removes the filter media from the oil filter system.	X	X															
Clean Filter Media	The interaction during which the maintainer cleans the filter media.	X	X															
Insert Filter Media	The interaction during which the maintainer inserts the filter media back into the filter housing.	X	X															
Roll Filter Element	The interaction during which the manufacturing system rolls the sheet filter element into a cylindrical shape.	X													X			
Transmit Shock & Vibration	The interaction during which the oil filter system is subject to, and transmits, mechanical shock and vibration originating externally.	X		X														
Monitor Filter	The interaction through which the service person or lubricated equipment monitors the condition of the oil filter.	X	X															
Prevent Vapor Leakage	The interaction through which the oil filter prevents undue quantities of gaseous vapor contaminants from reaching the external local atmosphere.	X			X													
Prevent Lubricant Leakage	The interaction through which the oil filter prevents undue quantities of lubricant from escape from its portion of the lubrication loop.	X					X		X									
Transmit Thermal Energy	The interaction through which the oil filter receives and transmits thermal energy, originating in external components.	X		X	X		X											

# Interaction: Filter Lubricant

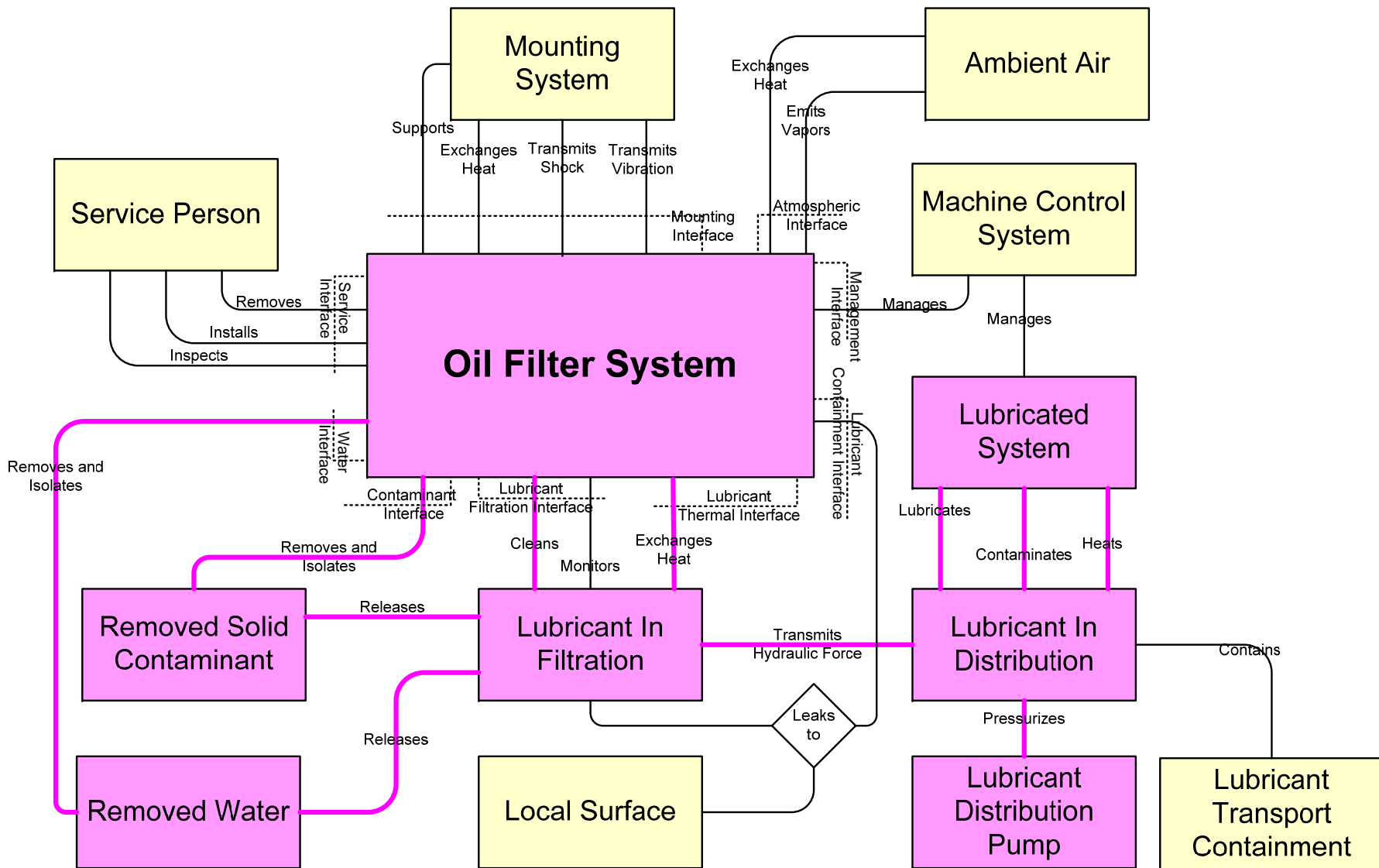

## Detail Interaction Model Diagram Style 1:

Media Flow-Through, Other Actors  
Interacting with Subject System

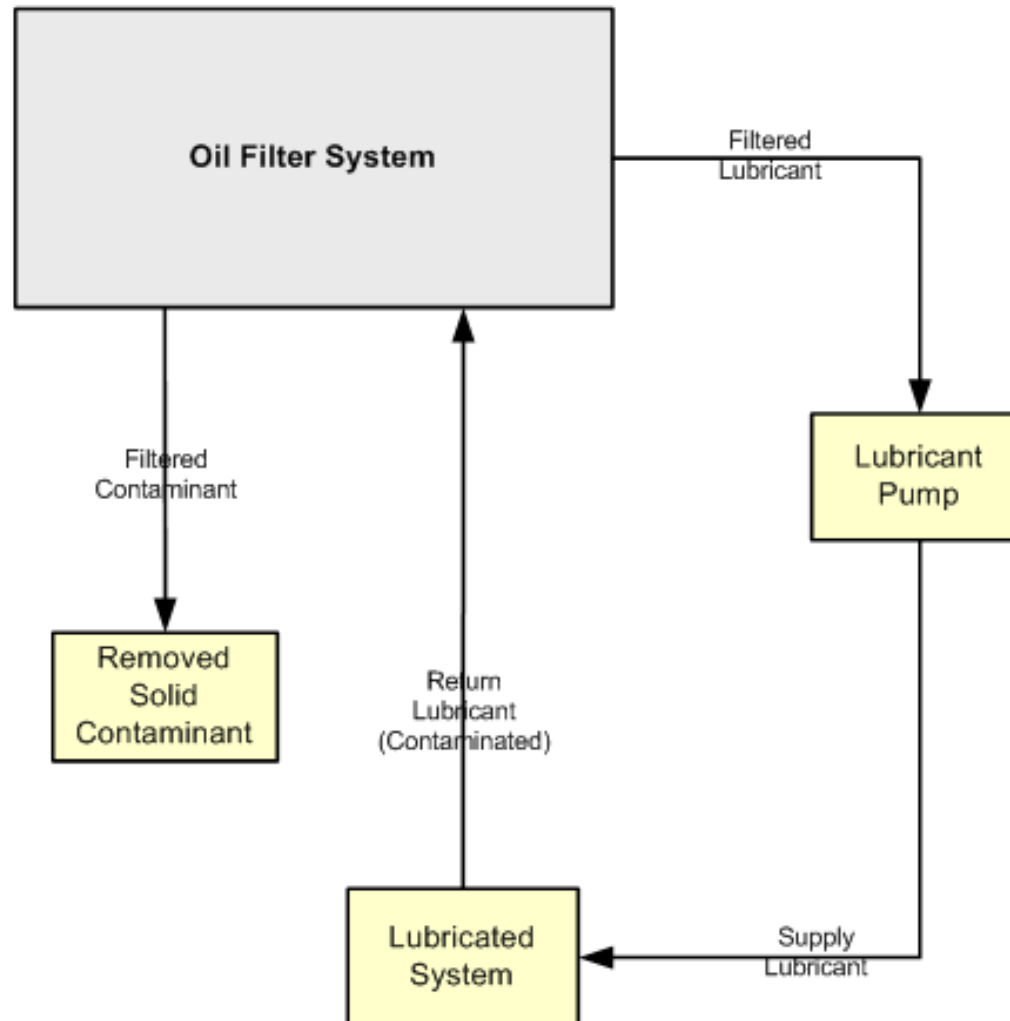



## Detail Interaction Model Diagram Style 2:

Media Itself Interacting Externally with  
Subject System

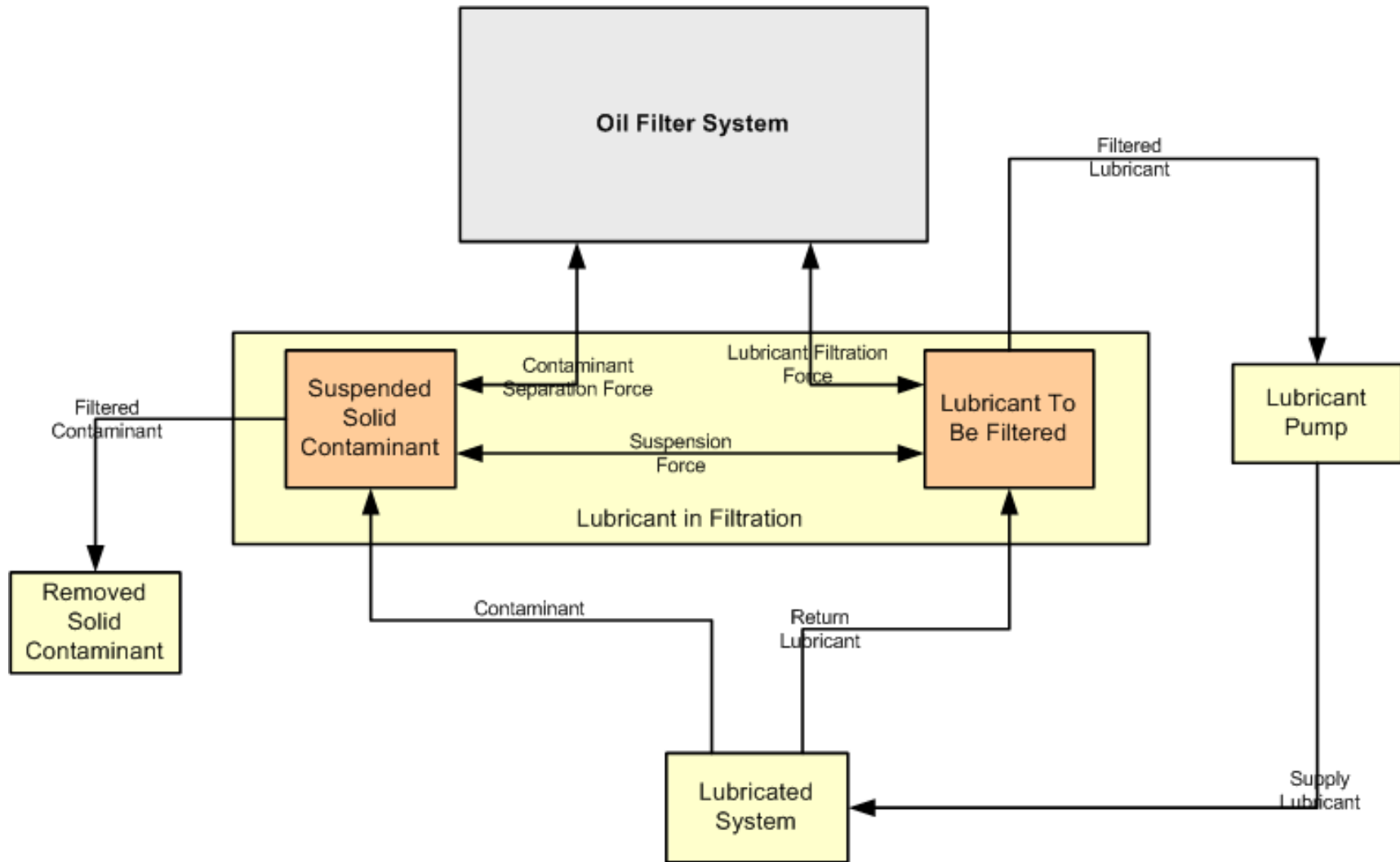

# Example S\*Pattern Logical Architecture Model

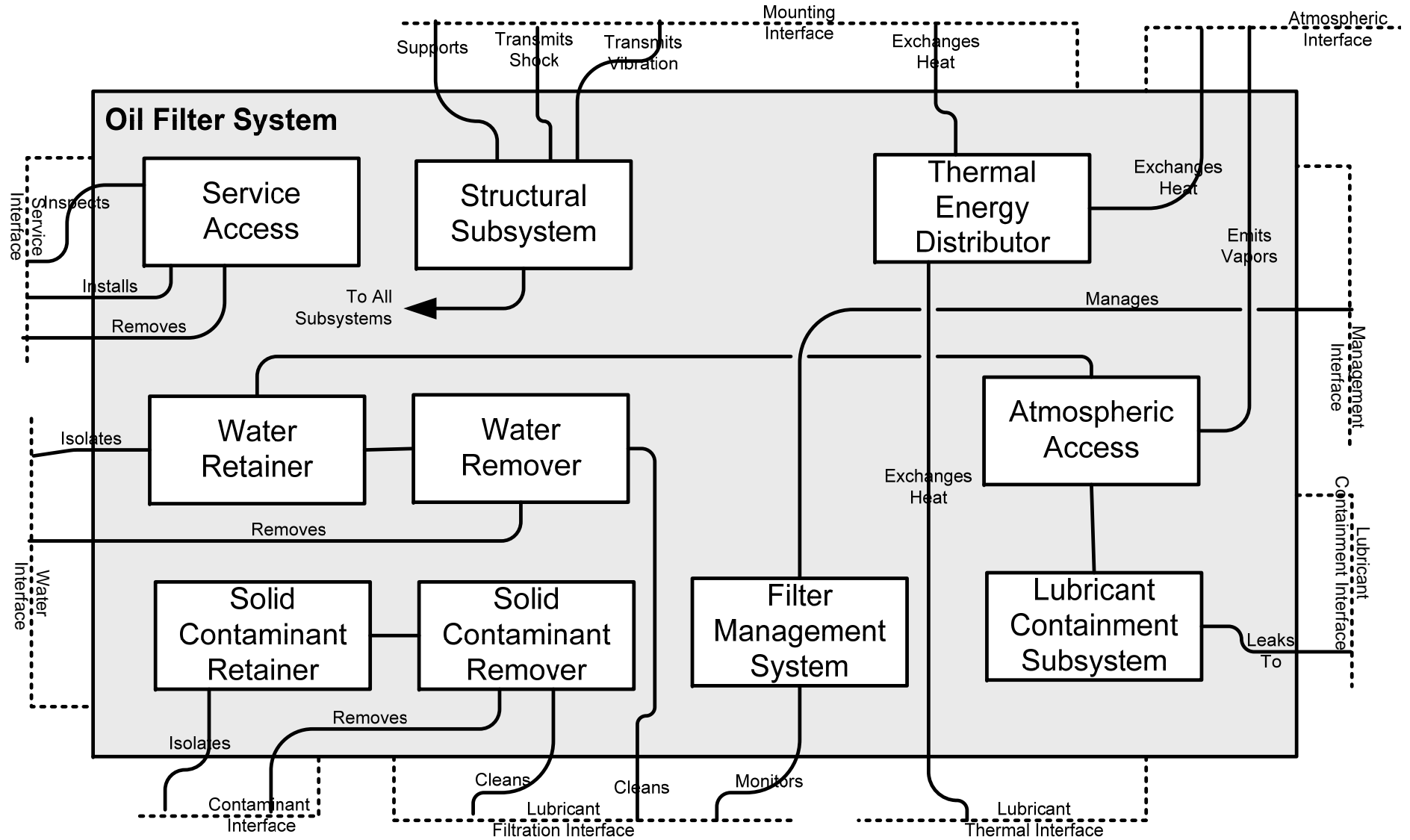

# Example S\*Pattern Requirements Model -- Extract

Interaction	Role	ID	Requirement Statement
Filter Lubricant	Oil Filter System	OF-50	For a Return Lubricant stream of [Lubricant Viscosity Range] and [Lubricant Pressure Range], the Oil Filter shall separate Filtered Contaminant particles from the Lubricant output stream, according to the [Filter Particle Size Distribution Profile].
Filter Lubricant	Oil Filter System	OF-51	The Oil Filter shall operate at lubricant pressure of [Max Lubricant Pressure] with structural failure rates less than [Max Structural Failure Rate] over an in-service life of [Min Service Life].
Filter Lubricant	Oil Filter System	OF-52	The Oil Filter shall accommodate a Lubricant flow rate of [Lubricant Flow Rate].
Filter Lubricant	Lubricant Distribution Pump	OF-53	The Pump shall maintain oil pressure within the [Lubricant Pressure Range].
Filter Lubricant	Lubricant In Filtration	OF-54	The Lubricant in Filtration shall have viscosity within the [Lubricant Viscosity Range].
Filter Lubricant	Lubricated Machine	OF-55	The Lubricated Machine shall contribute a Contaminant Load to the lubricant, not to exceed [Lubricant Contaminant Load Rate].
Filter Lubricant	Lubricated Machine	OF-56	The Lubricated Machine shall not heat the lubricant above [Max Lubricant Temperature].
Inject Additive	Oil Filter System	OF-57	The Oil Filter shall inject additive of type [Additive Type] into the Lubricant flow, at a rate of [Additive Injection Rate] per unit of lubricant flow, over the service life of the filter element.
Remove Filter Media	Oil Filter System	OF-90	The Oil Filter System shall permit the removal of its used Filter Media.
Remove Filter Media	Oil Filter System	OF-91	The Oil Filter System filter media removal process shall allow the service person to avoid direct contact contamination with filtered contaminants and lubricant.
Clean Filter Media	Oil Filter System	OF-92	The Oil Filter System shall permit the cleaning of its used Filter Media, for reuse purposes, using cleaning solvent and method of type [Filter Media Cleaning Method and Solvent].
Clean Filter Media	Oil Filter System	OF-93	The Oil Filter System filter cleaning process shall allow the service person to avoid direct contact contamination with filtered contaminants and lubricant.
Insert Filter Media	Oil Filter System	OF-94	The Oil Filter System shall permit the insertion of its Filter Media, of type [Filter Media Type].
Insert Filter Media	Oil Filter System	OF-95	The Oil Filter System filter media insertion process shall allow the service person to avoid direct contact contamination with filtered contaminants and lubricant.
Transmit Shock & Vibration	Oil Filter System	OF-100	The system shall meet its other requirements when subject to a vibration spectrum not exceeding [Max Vibration Spectrum] during its in-service life.
Transmit Shock & Vibration	Oil Filter System	OF-101	The system shall meet its other requirements when subject to shock intensity and frequency not exceeding [Max Shock Intensity and Frequency] during its in-service life.
Monitor Filter	Oil Filter System	OF-102	The system shall provide a means of inspection of its remaining service life before requiring servicing, using [Filter Monitoring Method].
Prevent Vapor Leakage	Oil Filter System	OF-103	When operating within its rated lubricant pressure and temperature, at altitudes not exceeding [Max Service Altitude], the system shall maintain Vapor Leakage to the ambient air space below [Max Vapor Leakage Rate].
Prevent Lubricant Leakage	Oil Filter System	OF-104	When operating within its rated lubricant pressure and temperature, at altitudes not exceeding [Max Service Altitude], the system shall maintain Fluid Leakage to the surrounding space below [Max Fluid Leakage Rate].
Transmit Thermal Energy	Oil Filter System	OF-105	The system shall meet its other requirements while operating in external ambient air temperatures of [External Temperature Range] and lubricant temperatures of [Lubricant Temperature Range].
Install Filter	Oil Filter System	OF-106	The Oil Filter shall be manually installable in ten minutes or less, using only a screwdriver.
Install Filter	Oil Filter System	OF-107	The Oil Filter shall have installation instructions printed on its exterior surface, in [National Language] language.
Install Filter	Oil Filter System	OF-110	The Oil Filter shall not present sharp edge hazards to the installer during the installation process.
Install Filter	Oil Filter System	OF-111	The Oil Filter shall be clearly labeled with instructions to shut down pressurized equipment prior to installation.
Install Filter	Service Person	OF-112	The Service Person with the visual acuity and hand strength of an average 40 year old adult shall be able to install the Oil Filter System.
Install Filter	Service Person	OF-113	The Service Person shall be capable of reading [National Language] at the tenth grade level.

# Pattern-Based Systems Engineering (PBSE)

- Pattern-Based Systems Engineering (PBSE) has two overall processes:
  - **Pattern Management Process**: Generates the general pattern, and periodically updates it based on application project discovery and learning;
  - **Pattern Configuration Process**: Configures the pattern into a specific model for application in a project.

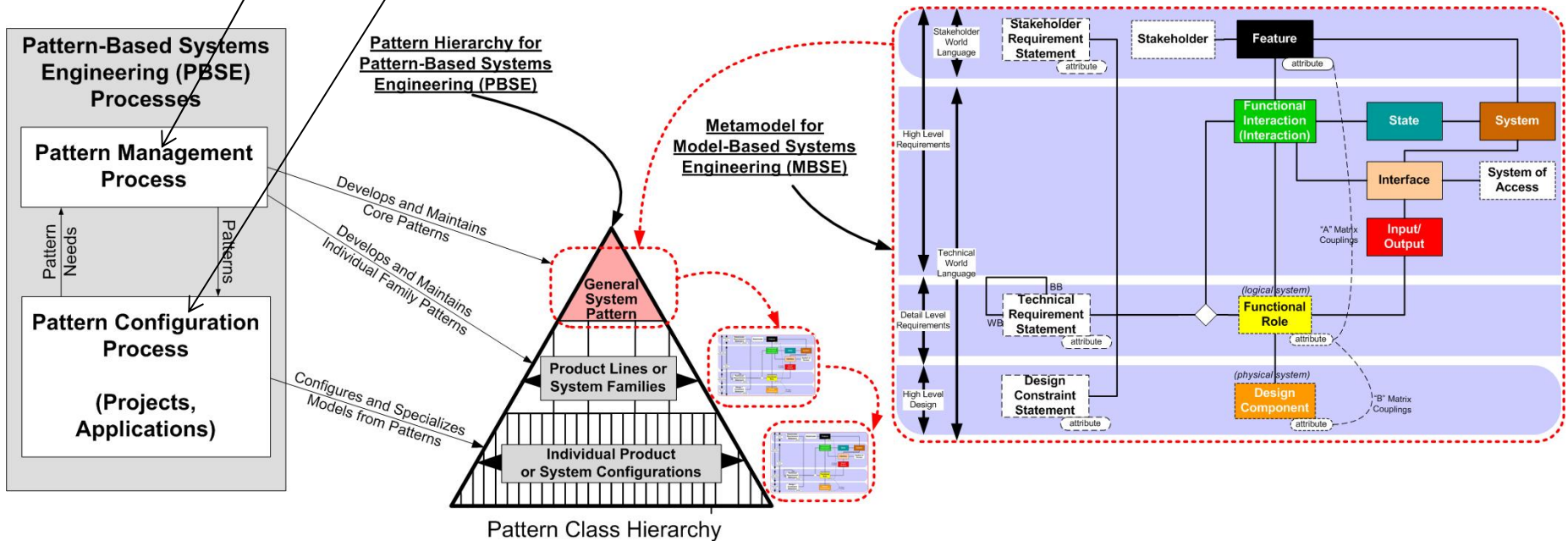

Business process optimized for PBSE fulfill a different vision:

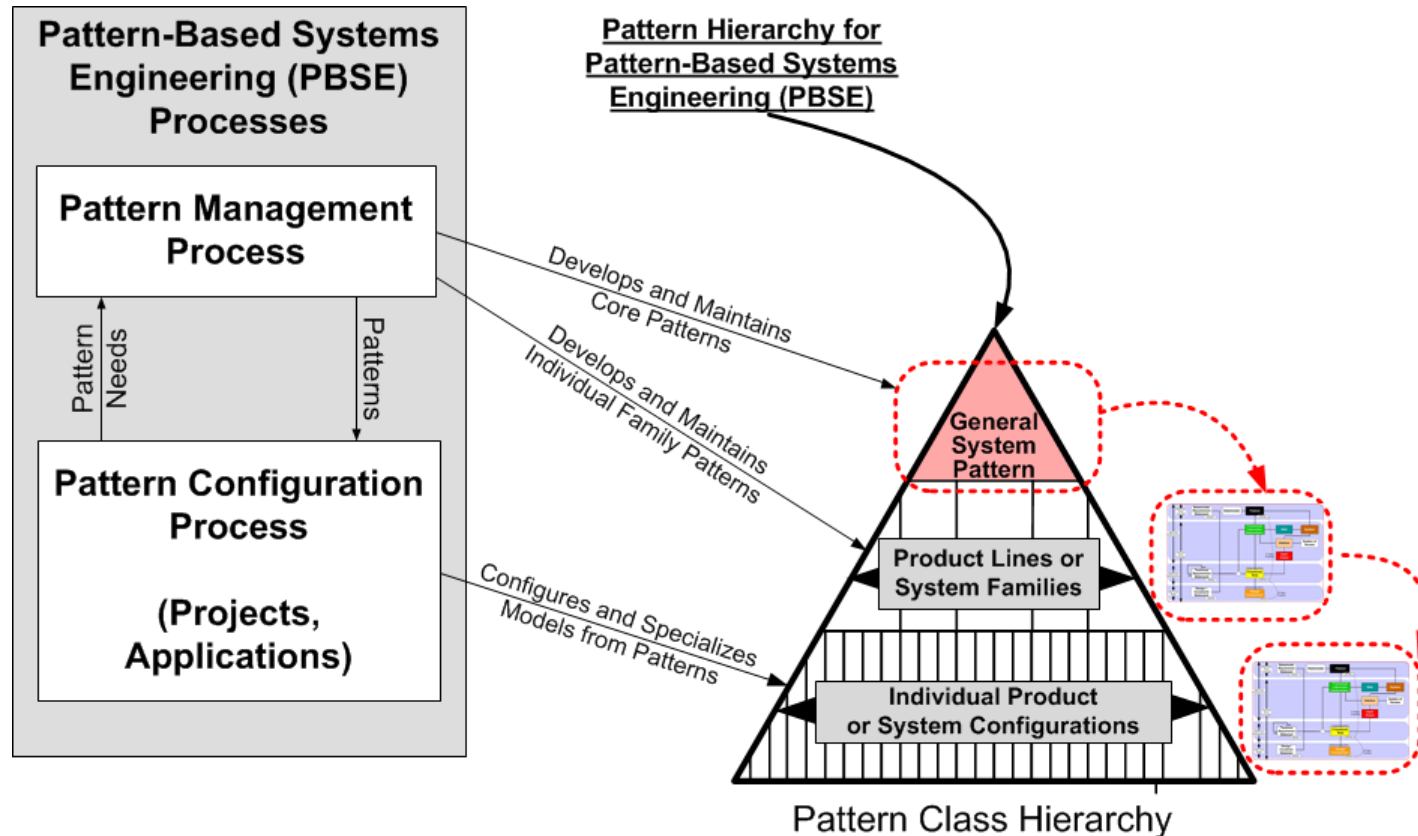

Why do most representations of the systems engineering process appear to assume starting from no formal knowledge about the system of interest & its domain?

# Pattern Configurations

Product/Feature	Ice Road Trucking	Consumer Auto	Commercial Auto	Fixed Based Engine
Engine Lubricant Filtration Feature	Cold Environment	Consumer Automotive	Commercial Automotive	Fixed Based Engine System
Mechanical Compatibility Feature	X	X	X	X
Cost of Operation Feature	X	X	X	X
Reliability Feature	X	X	X	X
Maintainability Feature	X	X	X	X
Additive Feature	No. 7 Efficiency Boost	No. 5 Life Extension	No. 6 Efficiency Boost	No. 3 Efficiency Boost
Environmentally Friendly Feature	X	X	X	X

# Pattern Configurations, Model Compression

- A table of configurations illustrates how patterns facilitate compression;
- Each column in the table is a compressed system representation with respect to (“modulo”) the pattern;
- The compression is typically very large;
- The compression ratio tells us how much of the pattern is variable and how much fixed, across the family of potential configurations.

Lawnmower Product Line: Configurations Table									
		Units	Walk-Behind	Walk-Behind	Walk-Behind	Riding	Riding	Riding Mower	Autonomous
			Push Mower	Mower	Self-Propelled	Rider	Tractor	Tractor	Autonomous
			Push Mower	Self-Propelled	Wide Cut	Rider	Lawn	Garden	Auto Mower
	Model Number		M3	M5	M11	M17	M19	M23	M100
	Market Segment		Sm Resident	Med Resident	Med Resident	Lg Resident	Lg Resident	Home Garden	High End Suburban
Power	Engine Manufacturer		B&S	B&S	Tecumseh	Tecumseh	Kohler	Kohler	Elektroset
	Horsepower	HP	5	6.5	13	16	18.5	22	0.5
Production	Cutting Width	Inches	17	19	36	36	42	48	16
	Maximum Mowing Speed	MPH	3	3	4	8	10	12	2.5
	Maximum Mowing Productivity	Acres/Hr			1.6				
	Turning Radius	Inches	0	0	0	0	126	165	0
	Fuel Tank Capacity	Hours	1.5	1.7	2.5	2.8	3.2	3.5	2
	Towing Feature						x	x	
	Electric Starter Feature				x	x	x	x	
	Basic Mowing Feature Group		x	x	x	x	x	x	x
Mower	No. of Anti-Scalping Rollers		0	0	1	2	4	6	0
	Cutting Height Minimum	Inches	1	1.5	1.5	1.5	1	1.5	1.2
	Cutting Height Maximum	Inches	4	5	5	6	8	10	3.8
	Operator Riding Feature					x	x	x	
	Grass Bagging Feature		Optional	Optional	Optional	Optional	Optional	Optional	
	Mulching Feature		Standard	Factory Installed	Dealer Installed				
	Aerator Feature					Optional	Optional	Optional	
	Autonomous Mowing Feature								x
	Dethatching Feature					Optional	Optional	Optional	
Physical	Wheel Base	Inches	18	20	22	40	48	52	16
	Overall Length	Inches	18	20	23	58	56	68	28.3
	Overall Height	Inches	40	42	42	30	32	36	10.3
	Width	Inches	18	20	22	40	48	52	23.6
	Weight	Pounds	120	160	300	680	705	1020	15.6
	Self-Propelled Mowing Feature			x	x	x	x	x	x
	Automatic TransmFeature							x	
Financials	Retail Price	Dollars	360	460	1800	3300	6100	9990	1799
	Manufacturer Cost	Dollars	120	140	550	950	1800	3500	310
Maintenance	Warranty	Months	12	12	18	24	24	24	12
	Product Service Life	Hours	500	500	600	1100	1350	1500	300
	Time Between Service	Hours	100	100	150	200	200	250	100
Safety	Spark Arrest Feature		x	x	x	x	x	x	

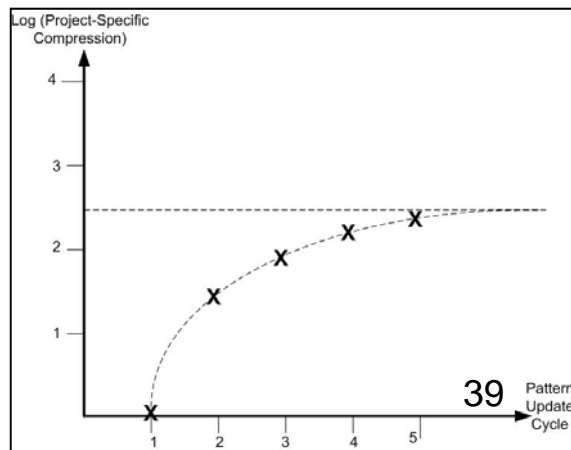
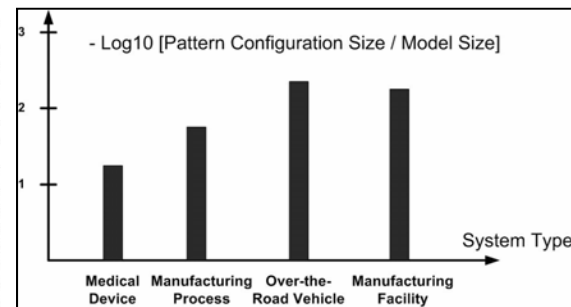

1. Eric Berg, "Affordable Systems Engineering: An Application of Model-Based System Patterns To Consumer Packaged Goods Products, Manufacturing, and Distribution", at INCOSE IW2014 MBSE Workshop, 2014.
2. Bill Schindel, Troy Peterson, "Introduction to Pattern-Based Systems Engineering (PBSE): Leveraging MBSE Techniques", in Proc. of INCOSE 2013 Great Lakes Regional Conference on Systems Engineering, Tutorial, October, 2013.
3. W. Schindel, "System Interactions: Making The Heart of Systems More Visible", in Proc. of INCOSE Great Lakes 2013 Regional Conference on Systems Engineering, October, 2013.
4. Bill Schindel, Troy Peterson, "Introduction to Pattern-Based Systems Engineering (PBSE): Leveraging MBSE Techniques", in Proc. of INCOSE 2013 International Symposium, Tutorial, June, 2013.
5. "Abbreviated Systematica Glossary, Ordered by Concept, V 4.2.2, ICTT System Sciences, 2013.
6. W. Schindel, "Introduction to Pattern-Based Systems Engineering (PBSE)", INCOSE Finger Lakes Chapter Webinar, April 26, 2012.
7. -----, "Integrating Materials, Process & Product Portfolios: Lessons from Pattern-Based Systems Engineering", in Proc. of 2012 Conference of Society for the Advancement of Material and Process Engineering, 2012.
8. -----, "What Is the Smallest Model of a System?", in Proc. of the INCOSE 2011 International Symposium, International Council on Systems Engineering (2011).
9. -----, "The Impact of 'Dark Patterns' On Uncertainty: Enhancing Adaptability In The Systems World", in Proc. of INCOSE Great Lakes 2011 Regional Conference on Systems Engineering, Dearborn, MI, 2011
10. -----, "Failure Analysis: Insights from Model-Based Systems Engineering", in *Proceedings of INCOSE 2010 Symposium*, July 2010.
11. J. Bradley, M. Hughes, and W. Schindel, "Optimizing Delivery of Global Pharmaceutical Packaging Solutions, Using Systems Engineering Patterns", in Proc. of the INCOSE 2010 International Symposium (2010).
12. W. Schindel, "Pattern-Based Systems Engineering: An Extension of Model-Based SE", INCOSE IS2005 Tutorial TIES 4, (2005).
13. -----, "Requirements Statements Are Transfer Functions: An Insight from Model-Based Systems Engineering", in *Proc. of INCOSE 2005 International Symposium*, (2005).
14. W. Schindel, and V. Smith, "Results of Applying a Families-of-Systems Approach to Systems Engineering of Product Line Families", SAE International, Technical Report 2002-01-3086 (2002)..



The references above may be downloaded from:

<https://sites.google.com/site/incosepbsewgtempaccess/>